

Celia Shower Mixer With Diverter

Nero

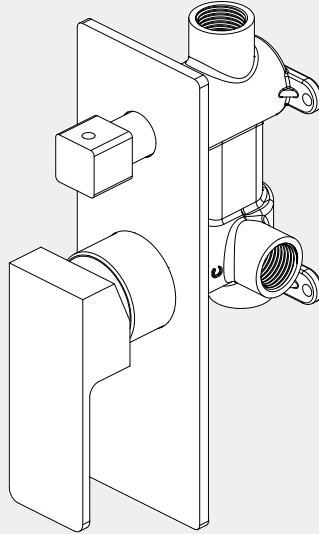

Lead Free



Version : 202508

Drawing

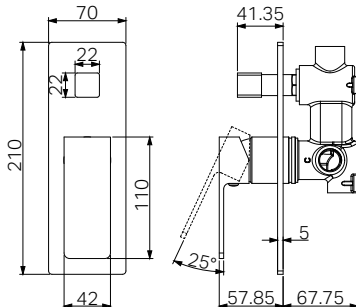

Specifications

Watermark License

WM-060073

Temperature Rating

Min 1 °C - Max 75 °C

Pressure Rating

Min 150kpa - Max 500kpa

Finish & SKU



Chrome
NR301511aCH



Brushed Nickel
NR301511aBN



Matte Black
NR301511aMB

Group Items

1x Universal Body

1x Trim Kits

*Dimensions are nominal measurements only.

INSTALLATION INSTRUCTIONS

GENERAL INSTRUCTIONS:

- This product must be installed by a licensed plumber. Ensure that your plumbing installation complies with the Australian/New Zealand Standard AS/NZS 3500.
- All pipework must be thoroughly flushed prior to the installation of the mixer. In-line filters must be fitted on both hot and cold supplies to prevent foreign particles from damaging the ceramic cartridge.
- All outlets used primarily for personal hygiene must deliver water at a safe temperature in accordance with regional regulations.

INSTALLATION STEPS FOR BODY

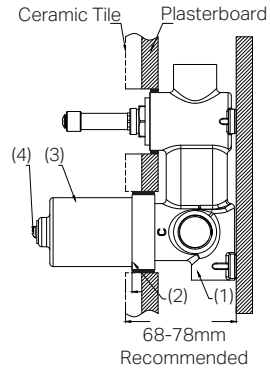
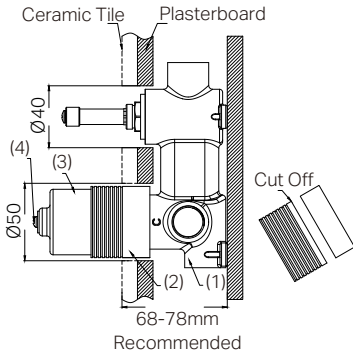

1. Secure the mixer body (1) to the nogging, ensuring an installation depth is 68-78mm from the nogging to ceramic tile.

NOTE: Do not remove protective sleeve (2) from the mixer body during installation.

2. Connect the cold and hot water supply lines and perform a leak test.

3. Drill a $\phi 50$ mm and a $\phi 40$ mm hole in the plasterboard for mixer body, and then position plasterboard as shown in the diagram above.

4. When the installation depth is 68-70 mm, position the protective sleeve (2) 2-4 mm from the ceramic tile surface to the body. When the installation depth is 71-78 mm, position the protective sleeve (2) 4-7 mm from the ceramic tile surface to the body. Then, waterproof the gap between the plasterboard and the body.

5. Remove the self-tapping screw, washer, and protective sleeve, and cut the protective sleeve along the marked point.

6. Reattach the self-tapping screw, washer, and protective sleeve.

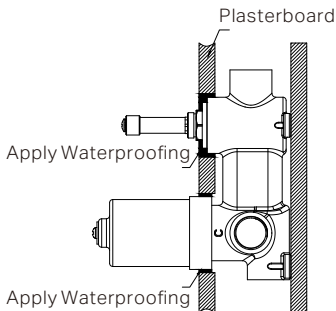

7. Waterproof for the gap between the plasterboard and body.

INSTALLATION STEPS FOR TRIM KITS

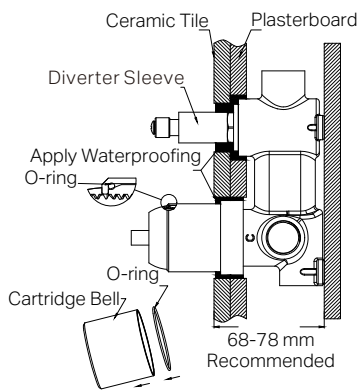
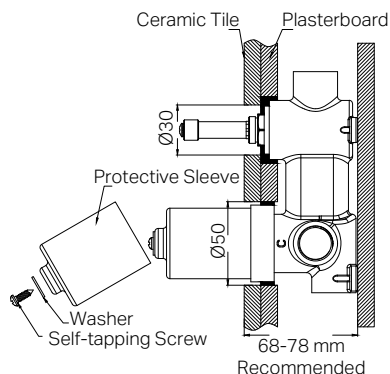

1. Drill a $\varnothing 50\text{mm}$ and a $\varnothing 30\text{mm}$ hole in the ceramic tile, then position it as shown in the diagram above.
2. Undo the self-tapping screw to remove the protective sleeve.

3. Insert the O-ring to the cartridge bell groove, and slide the cartridge bell onto cartridge and slide diverter sleeve onto diverter cartridge.
4. Apply waterproof treatment to the area indicated in the diagram above.
5. Thread the dressing cap on the cartridge bell.

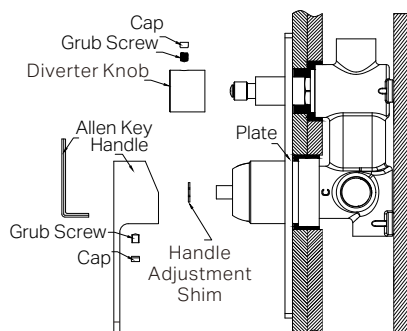

6. Install the back plate against the wall. Fit the handle adjustment shim onto the cartridge stem, attach the handle using a grub screw, and cover the grub screw hole with the cap.
7. Attach the diverter knob to diverter cartridge, tighten it with grub screw using Allen key, and cap the grub screw hole.

FINAL INSPECTION:

- Ensure the tap operates smoothly and that there are no leaks at the connections.
- Clean the area and the newly installed tap with a soft cloth to remove any installation residues.

MAINTENANCE AND CARE:

- Regularly check the mixer and connections for signs of wear or leaks.
- Clean the tap with mild soapy water to maintain its appearance, avoiding harsh chemicals and abrasive materials that may damage the finish.

Nero

